

ACCESSORI:

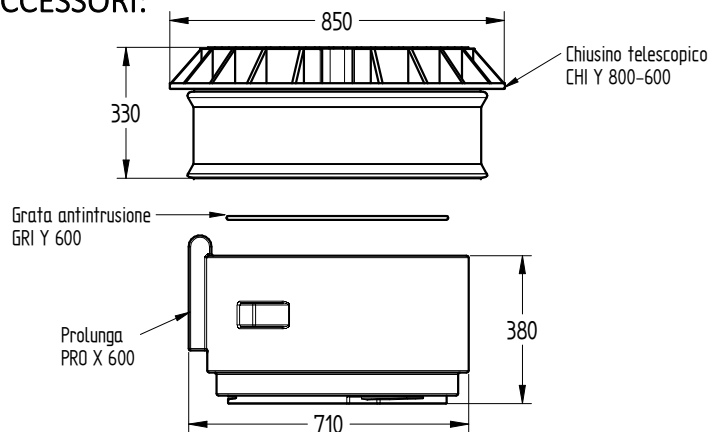

UFFICIO TECNICO



REVISIONE	MOTIVO	DATA
4		
3		
2		
1	Aggiornamento catalogo	
0	Emissione	

DISEGNATO	CONTROLLATO	APPROVATO
F. Grandicelli	P. Dell'Onite	P. Dell'Onite
© é vietata la riproduzione e/o la diffusione di questo documento, totale o in parte		
MATERIALE	PESO	SCALA
LLDPE	360 kg	1:50

**NOTA:**  
le quote e le dimensioni dei manufatti realizzati in P.E tramite stampaggio rotazionale, possono avere un tolleranza del +/- 3%